



Jay Series™, Select™ & Baja™

2008 Camping Trailers by Jayco®

Elevate Your Camping Trips



2008 JAY SERIES, SELECT, BAJA Camping Trailers by Jayco®



Jay Series



Select



Baja



AMERICA'S MOST LIVEABLE RV'S.



Jay Series, Select & Baja

2008 CAMPING TRAILERS

Who says roughing it has to be rough on your back? Get up off the ground and take camping to a whole new level with a Jay Series, Select or Baja camping trailer from Jayco. They're so affordable and simple to operate and maintain. They make it easy to upgrade from a tent. You'll enjoy having a few creature comforts with you while exploring the wilderness.

- » Above-floor, fully enclosed patented lifter system protects from road debris and the elements while driving
- » E-Z Lube® axles allow easy maintenance and low profile make towing a breeze
- » Seamless and domed fiberglass roof allows efficient water run-off and an impenetrable barrier
- » Corrosion-resistant E-Coat™ frame is easy to maintain
- » Sectionalized DuraTek™ tent material has double-stitched seams for extra strength
- » Fully undercoated floor and bed bases with sealed edges to repel moisture
- » Rugged diamond-plate panels on front and rear endwalls
- » Unparalleled 2-year Co-Pilot Warranty plus Lifetime Coverage on lifter system, roof, floor and frame



Jayco Makes Roughing It Go Much Smoother

Which Camping Trailer Fits Your Idea of Adventure?

Jay Series



- » Variety of floorplans that sleep 5 to 8
- » Jayco's most popular and affordable camping trailer
- » Family-friendly choices in furniture configurations
- » Great for first-time RVers

Select



- » Sleeps 5 to 6
- » Jayco's premier camping trailer
- » High walls for extra storage space and headroom
- » Includes the finest interior amenities

Baja



- » Sleeps 4 to 6
- » Jayco's camping trailer/toy hauler combination
- » Bike Port™ deck holds up to 6 bicycles, up to 3 dirt bikes or an ATV



Celebrating 40 Years of Liveability

The Jayco story began in 1968 with a humble desire to build more comfortable and practical ways for families to explore the world together. Jayco has grown to become the largest privately owned manufacturer of recreation vehicles in North America. While our product line is more diverse than ever before, every unit we build shares a common attribute — liveability. Because we believe every journey should be easy to enjoy.

Jay Series™



» For Camping the Whole Family Can Enjoy

Take a step up from tent camping (and raise everybody's level of fun) with an affordable Jay Series camping trailer from Jayco. Choose from six floorplans to find the right sleeping and dining accommodations for your family — then relax and discover just how comfortable camping can be.





Getting to and from campgrounds will be a breeze since Jay Series camping trailers feature E-Z Lube® axles and a low profile for easy towing.



Two bunk-end fan lights make the sleeping area feel more like home.



Speed through the set-up process thanks to sectionalized tents with a unique Velcro® tent-to-bunk attachment system.



Both the front and rear endwalls are built with rugged diamond-plate panels for durability.



A Great Year to Buy

With a 40-year reputation for excellence, there has never been a better time to buy a Jayco camping trailer. Jayco's production team includes Amish craftsmen who build with well-honed woodworking techniques passed down for generations. Skilled seamstresses produce our upholstery, bedding and draperies with great attention to detail. Our dedication to our craft is what allows us to offer industry-leading lifetime parts and labor coverage on our lifter system, roof, floor and frame. We also offer five-year (5) coverage on our tent. That's just another reason why our 40th Anniversary is a great year to buy a camping trailer.

Select™





» For Added Space and Extra Conveniences

The high-walled Select gives you more of what you want most in a camping trailer, including kitchen conveniences, headroom and storage inside and out. Now you can enjoy the sights and sounds of nature without giving up all the comforts of home.



The Select's kitchen area features a double bowl sink, 3 burner range with oven, raised panel cabinetry and a standard microwave.



The 200-lb. capacity lockable storage trunk gives you a spot for large items and helps keep your living space clutter-free.



Keep your food items cold and fresh (without depending on coolers) with the 3 cu. ft. gas/electric



Jayco's optional portable gas grill attaches quickly whenever your family is hungry for a cookout.

Baja™



» For Off-Road Adventures That Require Toys

Take the Baja camping trailer along on your next “middle of nowhere” hunting, fishing or off-roading trip, and you’ll be equipped for anything. The Bike Port™ deck, with 1200-lb. capacity, holds up to 6 bicycles, up to 3 dirt bikes or an ATV. Inside, there’s plenty of storage for your gear as well as comfortable spots to kick back and relax.



tread lightly!®

OFFICIAL SPONSOR



Jayco proudly sponsors Tread Lightly!®, a nonprofit organization whose mission is to empower generations to enjoy the outdoors responsibly through education and restoration.



Plug your iPod® into the dock and enjoy your favorite tunes with family or friends on the built-in stereo system.



For smoother trips through rugged terrain, Baja camping trailers are built with 13 inches of ground clearance plus leaf springs and shock absorbers.



Choose the optional diamond-plate toolbox for a handy place to store all your tools and gear.

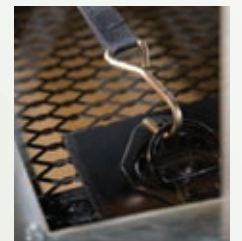

Six D-rings on the front deck safely secure your bikes or ATV.

Jayco Builds Lasting Value

The Jay Series, Select and Baja camping trailers are constructed with high quality materials using production techniques perfected over the past 40 years. Count on yours to look good, perform well for years and provide excellent resale value.



1. Plywood construction adds stability to roof
2. Domed fiberglass roof built with no center seam for better water runoff
3. White powder-coated bed bow keeps tent secure
4. Two-piece extruded aluminum bed frame
5. Undercoated plywood decking under tent
6. Tents are designed for lasting strength and easy set-up
7. Crank-down stabilizer jacks with sand pads
8. One-piece aluminum exterior sidewall
9. Sewn-in lifter post covers provide quick and easy set-up
10. 1/8" plywood adds strength to walls
11. Rounded one-piece polyethylene wheel wells
12. E-Z Lube® axles make maintenance a snap
13. One-piece entrance door
14. Retractable, skid-resistant step
15. Easy-care vinyl flooring throughout the interior
16. Undercoated floor deck constructed of Structurwood®
17. Rugged diamond-plate panels used on front and rear endwalls
18. Heavy duty A-frame construction

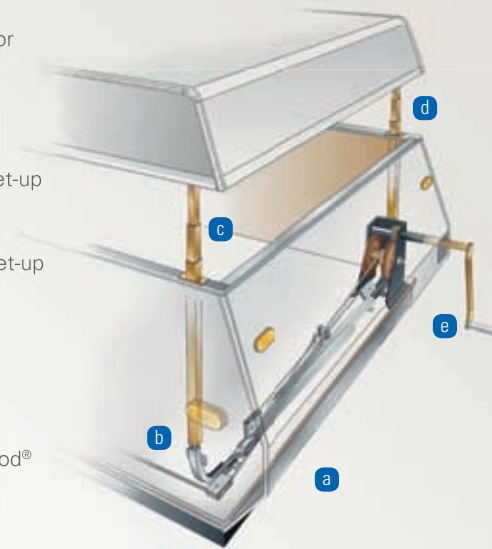

- a. Fully enclosed above the floor, Jayco's roof lifter system eliminates rust and potential damage from road debris and weather, and prevents rodent or insect access.
- b. Easy-to-use design featuring strong and flexible push-rods to guide the roof up as you crank.
- c. Tubular lifter posts have no edges to chafe or soil the tent, and no openings to catch fingers and cause injury.
- d. Nylon bushings in the lifter posts reduce friction and extend the life of the lifter system.
- e. Quick, comfortable setup is yours thanks to the ergonomic height of the crank and its smooth operation.

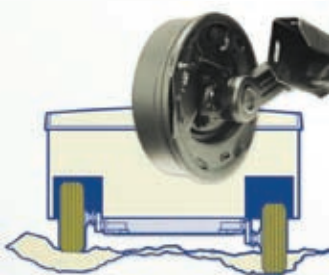

The Select camping trailer features TorFlex® torsion-axle suspension to simplify towing.



Frames are protected from corrosion by the 12-stage E-Coat™ finishing system.

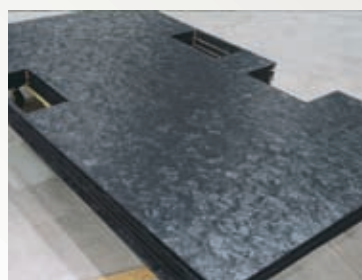

Single-piece Structurwood® floor and bed platforms are undercoated and edge-sealed to repel moisture.



Jayco's dedicated production team includes Amish craftsmen who build with well-honed woodworking techniques passed down for generations.

Camping Trailer Standards and Options

	JAY SERIES	SELECT	BAJA		JAY SERIES	SELECT	BAJA		JAY SERIES	SELECT	BAJA
Customer Value Package											
2-cu.ft. 3-way gas/electric refrigerator (110V/12V/Propane)			•								
7-spoke polished aluminum wheels			•								
AM/FM/CD stereo			•								
Battery gauge			•								
Bunk-end fan lights (2)			•								
iPod® adapter			•								
Self-storing awning made by Jayco®			•								
Water purification system			•								
Standard Exterior Equipment											
110V G.F.C.I. protected exterior receptacle			•								
12" C-range tires (806, 1007)			•								
13" C-range tires (1006, 1207, 1206)			•								
D-range tires (14" on 12HW, 15" on 14HW)			•								
14" x 14" roof vent			•								
15" black steel rims			•								
15" off-road Dunlop® Mud Rover radial tires			•								
20-lb. propane gas bottle			•								
Bed bases are undercoated			•								
Bumper made with welded steel construction (select models)			•								
Bumper is welded tube powder coated white (select models)			•								
Cast aluminum 110V G.F.C.I. protected exterior receptacle			•								
Crank-down stabilizer jacks with sand pads			•								
Diamond-plate walls on front and rear (12HW)			•								
Domed, fiberglass roof with no center seam			•								
Double aluminum exterior sidewalls (12HW)			•								
D-rings (6) welded to front storage deck			•								
DURATEK™ water-repellent sectionalized tent			•								
E-Coat™ protected frame			•								
Electric brakes (select models)			•								
Entrance door access with roof lowered			•								
Entrance door caddy			•								
Entrance door is 1-piece construction			•								
Exterior entrance door storage with securement strap			•								
Extrusions for box top are painted (powder-coated) black with black corner caps			•								
Extrusions for box top are painted (powder-coated) white with white corner caps			•								
E-Z Lube® axles			•								
Front ABS cap (14HW)			•								
Floor is undercoated and constructed of edge-sealed Structurwood™			•								
Front storage deck with expanded steel surface and aluminum deck railing			•								
Jayco's original, fully enclosed lifter system (same design used since 1968)			•								
Lamilux 4000 fiberglass laminated sidewalls (14HW)			•								
Leveling jacks and heavy-duty A-frame construction			•								
Lifter post covers integrated into tent			•								
Light in front trunk			•								
Moto graphics			•								
Standard Kitchen Equipment											
3-cu.ft. 3-way gas/electric refrigerator (110V/12V/Propane)			•								
6-gal. water heater (N/A 806)			•								
Appliances are pre-plumbed for propane			•								
Carry-out dinette table			•								
Domestic 2-burner stove/oven with recessed stove ring (14HW)			•								
Fluorescent light above sink			•								
Microwave oven			•								
Oversized oven			•								
Recessed 3-burner range with hinged cover (12HW)			•								
Spice rack			•								
Stainless steel double bowl sink and faucet			•								
Stainless steel carryout stove (2-burner, depending on model)			•								
Tray for silverware			•								
Standard Heat, Power and Water											
12V electrical system with 20-amp. 110V converter			•								
12V electrical system with 30-amp. 110V converter			•								
16,000 BTU Furnace			•								
17 gal. fresh water system with 12V demand pump			•								
30ft 30 amp power cord			•								
Double 20-lb. gas bottles, with vinyl cover			•								
Hookup for city water			•								
Porta-potti storage cabinet (N/A 806, 1207)			•								
Water heater bypass system			•								
Standard Interior Equipment											
110V G.F.C.I. protected interior receptacle			•								
12V high-intensity lighting			•								
Automatic cut-off switch for interior lights			•								
Bar for hanging clothes			•								
Bed flaps that cover edge of bed			•								
Hardwall bath/shower with cassette toilet (14HW)			•								
Booth dinette			•								
Brushed nickel hardware			•								
Bunk end fan lights (2)			•								
Cable TV hookup with RG6 connection			•								
C-clamp connection on tent supports			•								
Coordinated furniture, designed and made by Jayco®			•								
Cup holders installed throughout			•								
Door pulls with roller catch			•								
Drawers are made of real wood with nylon guides			•								
Floor-level courtesy lights			•								
Granite-look countertop			•								
Heavy-duty entrance door securement latches			•								
Hinged dinette seat bases			•								
J-Steel™ sofa (1006, 1206)			•								
Manchester Oak raised panel cabinetry			•								
Mildew resistant aluminum ceiling			•								
Modern interior designed and made by Jayco®			•								
Standard Safety Equipment											
1200 lb. front deck capacity			•								
Breakaway switch			•								
Carbon monoxide alarm			•								
Dual hitch safety chains			•								
Fire extinguisher			•								
Propane alarm			•								
Optional Equipment											
Attic fan			•								
16,000 BTU furnace with auto-ignition			•								
Bath/Shower option (select models)			•								
CSA Standards			•								
Customer Value Package			•								
Deluxe screen room (12HW)			•								
Drawer for exterior storage (12HW)			•								
Electric brakes (std 1206)			•								
Extra table with pedestal leg (1007 & 1207)			•								
Front storage box			•								
Heated bed mats (2)			•								
Hydraulic surge brakes			•								
Portable, outside gas grill			•								
Roof vent			•								
U-Dinette (806)			•								

	Floorplans	Exterior Length	Campsite Length	Approx. Travel Height	Unloaded Vehicle Weight (lbs.)	Dry Hitch Weight (lbs.)	Gross Vehicle Weight Rating (lbs.)	Cargo Carrying Capacity (lbs.)	Fresh Water Capacity (gal.) Includes Water Heater	Sleeping Capacity
Jay Series	806	11' 10"	16' 2"	53"	1380	165	2000	620	17	5-6
	1006	16' 9"	20' 10"	54"	1915	235	2950	1035	23	6-8
	1007	14' 2"	20' 4"	54"	1690	185	2350	660	23	6-8
	1008	16' 2"	20' 10"	56"	1915	175	2950	1035	23	6
	1206	18' 8"	23' 4"	56"	2340	310	3450	1110	23	6-8
	1207	16' 2"	23' 4"	56"	1885	205	2950	1065	23	6-8
	Select	12HW	18' 9"	22' 10"	62"	2760	290	3750	990	23
14HW		20' 1"	24' 10"	68"	3205	285	4550	1345	24	6-8
Baja	10Y	19' 8"	20' 10"	66"	2320	220	4550	2230	23	4-6

It is important for your safety and enjoyment that your tow vehicle be adequately sized and equipped to tow and handle the GVWR of the RV you select. Review weights and rating of your tow vehicle and consult a competent advisor for questions or advice. Whether you are new to RVing or a veteran, get a feel for the performance of your tow vehicle and the RV together before heading out on the roadways. When you tow an RV, you must drive differently than you do when driving a single vehicle. Practice hooking up, driving, backing up and braking in a safe environment or seek out professional instruction. Jayco affixes a weight label to each RV which lists weight information for that vehicle. See specification chart above.

Unloaded Vehicle Weight (UVW): Sometimes referred to as "Dry Weight," UVW means the typical weight of this trailer as built at the factory. The UVW, as used in product literature and other promotional materials, does not include cargo, fresh water, propane, options or dealer-installed accessories.

Gross Vehicle Weight Rating (GVWR): GVWR means the maximum permissible weight of the trailer, including the UVW plus passengers, personal items, all cargo, fluids, options and dealer-installed accessories. The GVWR is equal to or greater than the sum of the UVW and the CCC.

Cargo Carrying Capacity (CCC): CCC means the maximum weight of all passengers, personal items, food, fresh water, propane, tools, other cargo and dealer-installed accessories that can be carried by the trailer. CCC is equal to or less than GVWR minus UVW. The addition of options will decrease the CCC.

Hitch Weight (HW): The hitch weight, as used in product literature and other promotional materials, does not include cargo, fresh water, propane gas, options or dealer-installed accessories. The addition of these types of items will either add to or subtract from the stated hitch weight.

Jay Series

806

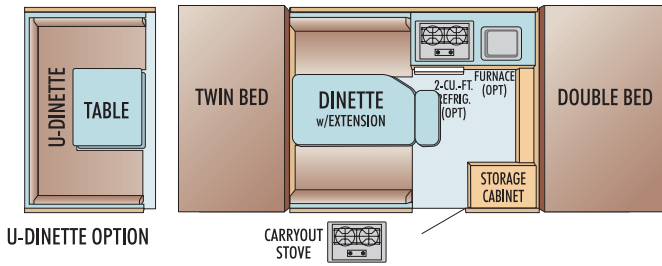

U-DINETTE OPTION

1006

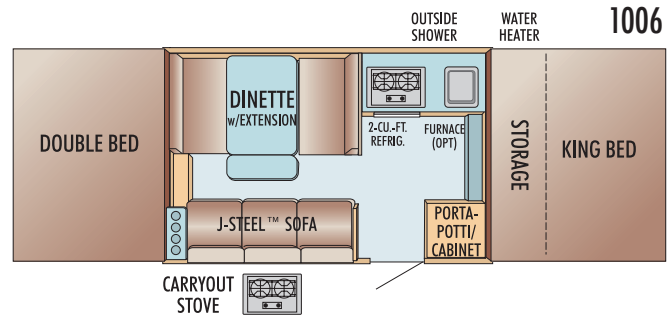

CARRYOUT STOVE

1007

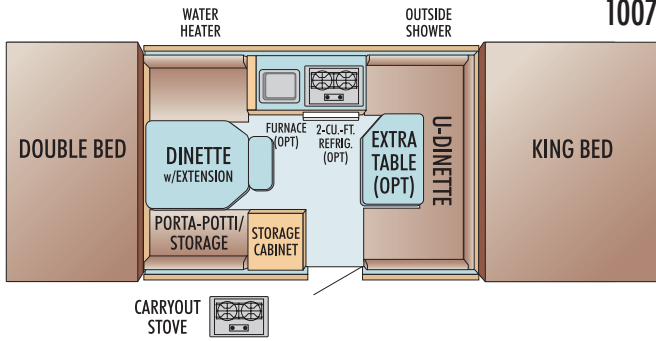

CARRYOUT STOVE

1008

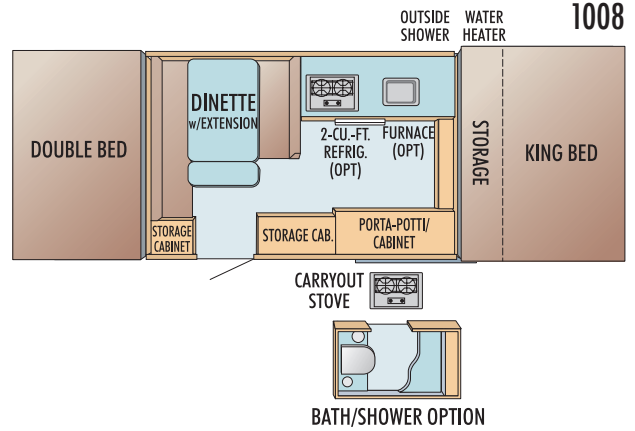

CARRYOUT STOVE

BATH/SHOWER OPTION

1206

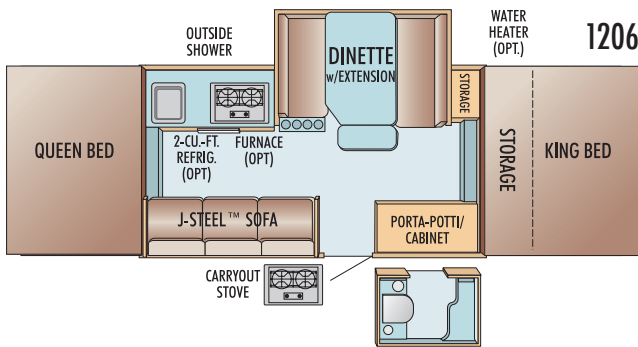

CARRYOUT STOVE

BATH/SHOWER OPTION

1207

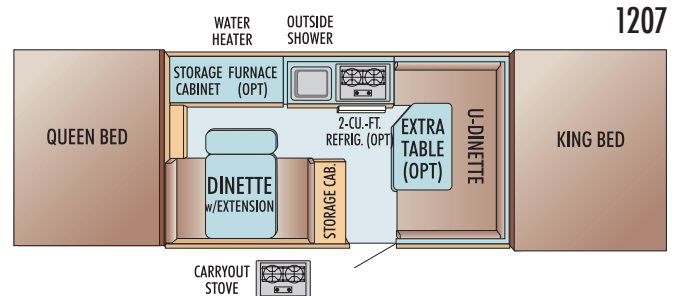

CARRYOUT STOVE

Select

12HW

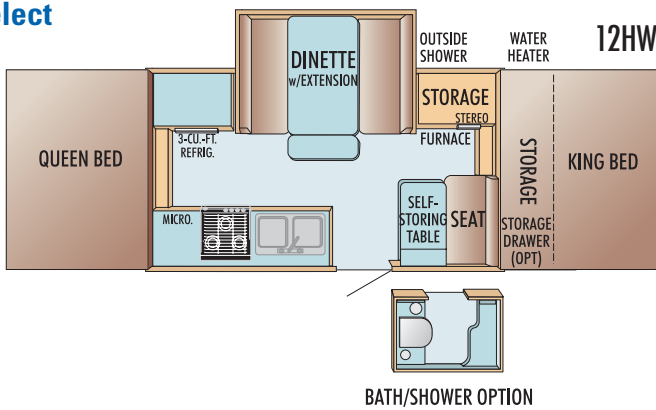

BATH/SHOWER OPTION

Baja

10Y

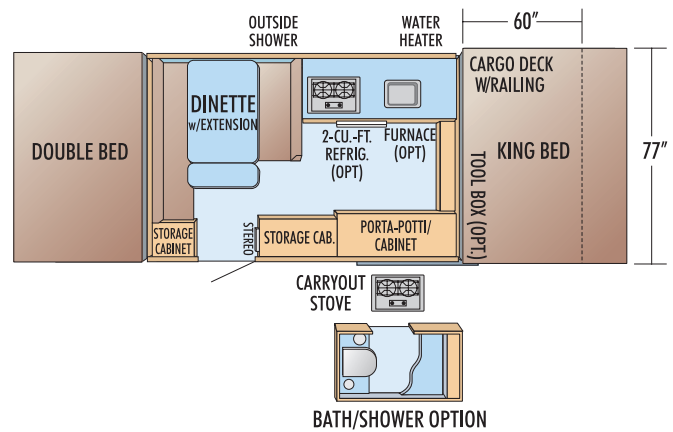

CARRYOUT STOVE

BATH/SHOWER OPTION

14HW

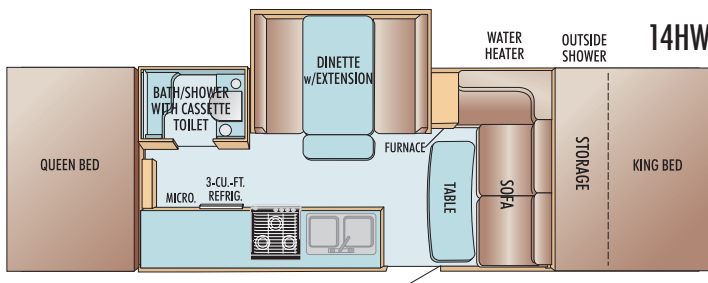

Best Warranties in the Business



The Jayco Co-Pilot Warranty is a manufacturer's limited warranty. It comes from the people who build Jayco recreation vehicles to the people who buy them. Each Jayco is warranted to the original purchaser for twenty-four (24) months or twenty-four thousand (24,000) miles (mileage limitation applies to motorized products only), whichever occurs first, from the original date of purchase against defects in materials and workmanship. Jayco's limited warranty is not transferable. Go ahead and compare the Jayco warranty with other manufacturers' warranties. You'll find it's the best in the business!

For a copy of the limited warranty with full terms and conditions, ask your local Jayco dealer.



Jayco offers to the original purchaser of any of our camping trailers an additional industry-leading lifetime parts and labor coverage on our lifter system, roof, floor and frame. We also offer five-year (5) coverage on our tent with parts, labor and freight covered the first two years; parts, factory labor and return freight during years three, four and five.

Customer First Roadside Assistance

Travel worry-free in your Camping Trailer with Jayco's Customer First Roadside Assistance program, yours at no cost during your first year of ownership. This program is offered through Coach-Net®, the largest RV emergency road service in the country, and gives you immediate access to dependable roadside assistance and support services with a simple phone call.

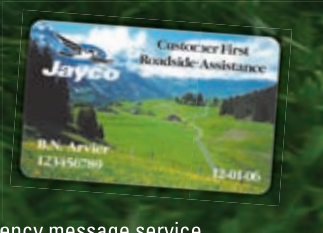

- Free jump starts
- Free tire changes
- Free fuel delivery
- Free lockout service
- Free traveler's checks
- 24-hour toll-free emergency message service
- Toll-free nationwide service appointment assistance
- Free custom trip routing and full color map service
- Free dispatch of on-site mechanical service
- \$1,000 auto theft or hit-and-run reward
- \$2,000 trip interruption reimbursement

Your Jayco Dealer

JayPlus

Protect your RV investment. Ask your Jayco dealer about our exclusive JayPlus program today.



As a Jayco owner, you can be part of the Jayco Jafari International Travel Club. Ask your dealer about the Jafari "flight" in your area, write Jayco or visit our website.



AMERICA'S MOST **LIVEABLE** RVs.

Jayco, Inc., P.O. Box 460, Middlebury, IN 46540 www.jayco.com

See dealer for further information and prices. All information in this brochure is the latest available at the time of publication approval. Jayco reserves the right to make changes and to discontinue models without notice or obligation. Photos in this brochure may show optional equipment or props used for photography purposes. RVs built for sale in Canada may differ to conform to Canadian codes. E-Z Lube is a registered trademark of the Dexter Axle Company. Carefree is a registered trademark of Carefree of Colorado. Dolby and the double-D symbol are registered trademarks of Dolby Laboratories.

©2007 Jayco, Inc. 08-FDCT-PL 1207-50K Printed in U.S.A. RVIA